

JAGULAR INDUSTRY LTD. has been established in 1986. Base on the excellent technologies and R&D capability, we manufacture and provide a wide range of high quality grinding machines for various grinding applications. In order to provide our customers' more selection and better services, we have been continuously enhancing our grinding technique and improving the mechanism design. In the beginning, we manufactured punch grinder and various internal and external grinding machines. After over 30 years' continuous effort, we now can manufacture full range of CNC internal and cylindrical grinding machines, CNC internal grinding machine, CNC cylindrical grinding machine, CNC centerless grinding machine, variety of precision micro internal and external grinding machine and precision knife grinder. The most variety of grinding machines can satisfy all our clients. We sell our grinding machine under the brand name "JAGURA" all over the world.

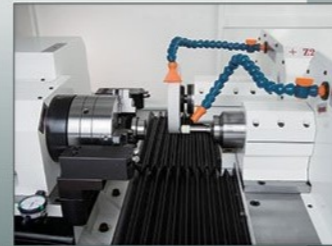

INTERNAL & CYLINDRICAL GRINDER (CARBIDE DIE SERIES)

- ICG-S200
- ICG-SL200
- ICG-SL210
- ICG-SL410



INTERNAL & CYLINDRICAL GRINDER (IN-LINE SERIES)

- ICG1512 SL11 SL20
- ICG2012 SL11 SL20
- ICG2512 SL11 SL20



CNC INTERNAL GRINDER

- IG06 • IG35100
- IG50 • IG35150
- IG80 • IG35200
- IG150



CNC CYLINDRICAL GRINDER

- CG175 • CG3250
- CG2535 • CG3260
- CG2550 • CG3275
- CG2575 • CG32100
- CG3240 • CG32120

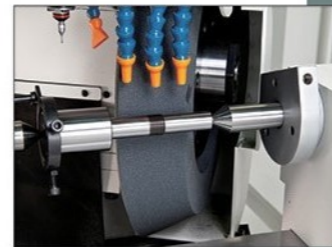

CNC CYLINDRICAL GRINDER (ANGULAR TYPE)

- CGA2535
- CGA2550
- CGA3545
- CGA3565



CNC CENTERLESS GRINDER

- 12C • 20C • 24C
- 18C • 2010C • 2410C
- 1810C • 2012C • 2412C
- 1812C



**INTERNAL & CYLINDRICAL GRINDING MACHINE
IN-LINE SERIES**



JAGULAR INDUSTRY LTD.
400. Shin Hwa 1 Road. Tan-Tzu
Taichung, Taiwan, R.O.C.
Tel: 886-4-25347465 · 25310646
Fax: 886-4-25340191
E-mail: jagura@ms17.hinet.net
<http://www.jaguraweb.com>



Reaching you... Worldwide
JAGULAR INDUSTRY LTD.

The most important feature of **JAGURA** CNC internal & cylindrical grinding machine is the grinding unit can be designed according to the customer's workpiece. Customized design ability is what we are most proud of. In the application of **internal grinding, external grinding and end-face grinding**, Jagura provides the total solutions to customers. Jagura can not only design mechanism structure according to workpiece clamping swing and workpiece length, but also set spindle working position layout according to customer's requirement. Moreover, regarding workpiece clamping, Jagura provides several clamping methods, such as hydraulic soft chuck clamping, collet clamping, roller workhead clamping, diaphragm chuck clamping, 3 jaw chuck clamping and magnetic chuck clamping. As to the control system, Jagura develops two control systems. Easy CNC & CNC for different grinding applications.

Grinding ID/OD parts let's talk

*Collet industry/Gear industry/Bush industry/Automobile industry/
Hydraulic & pneumatic industry/Mold & Die industry*

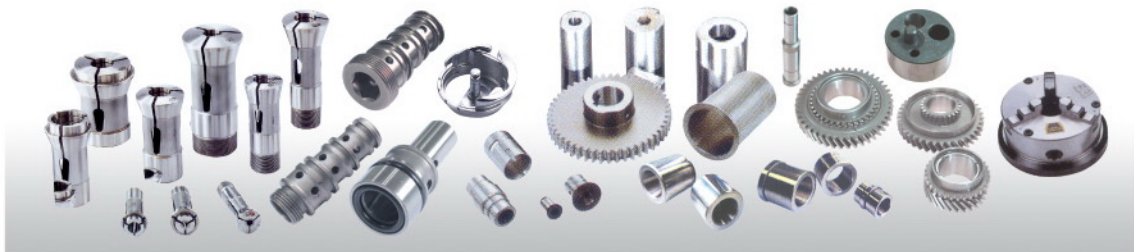

Easy CNC / CNC In-Line Series



Machine Design & Build

Machine Bed:

The machine bed is constructed of high quality "MEEHANITE" cast iron and has been heat treated, normalized and precision ground for maximum stability and rigidity. Outstanding structural reinforcement assures distortion-free operation and long life.

Slide-ways & Feed axes:

The double V slide design reinforces the feeding stability. Handscraped slideways is provided for all axes, turcite coated surface for upper slide, automatically lubricated, assure low friction movement.

The X-axis, Z1-axis & Z2-axis are equipped with precision ballscrews and servo motors. A servo motor drives the ballscrew directly guaranteeing positioning accuracy and feeding stability.

Workhead:

The workhead spindle runs on high precision roller bearings featuring high accuracy, rigidity and silent running.

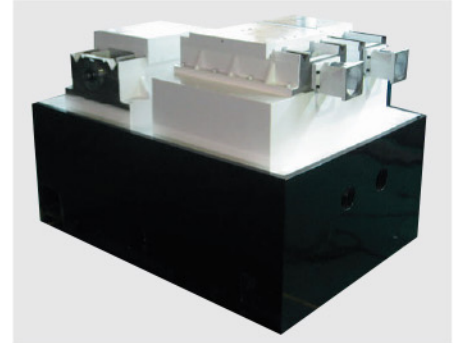

Machine Bed/Slide-Way/Feed axes

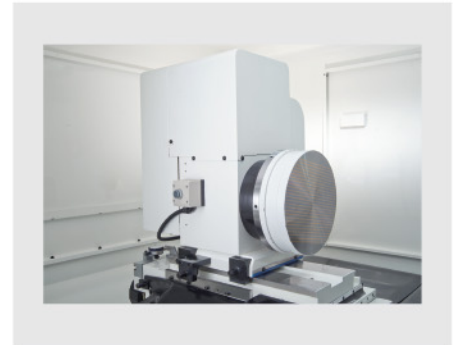

Work head

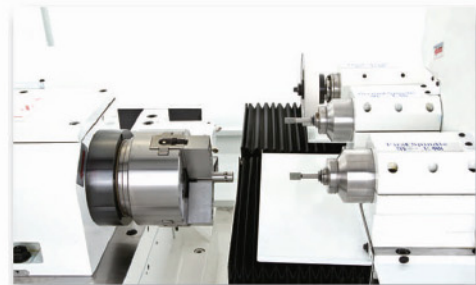
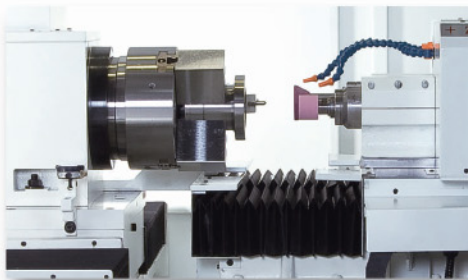

Easy CNC Software & Dialogue Hmi (Human Machine Interface)

JAGURA EASY CNC Series Internal & cylindrical grinding machines are specially designed for ID, OD and end-face grinding. The **EASY CNC** control system is constructed by DELTA but it employs the exclusive advanced software developed by **JAGURA**.

JAGURA Dialogue HMI is easy to both learn and use, thereby saving JAGURA EASY CNC users valuable training time as well as money. The **JAGURA** Dialogue HMI is divided into 4 main sections: Main Menu, Dressing Programs, Grinding Path Programs, and Program Links. Users simply select a dressing pattern and grinding path, start to work. **JAGURA** Dialogue HMI is the best solution for grinding, The graphic directory enables the user to divide complicated grinding processes into individual stages. First, one of the pre-loaded grinding programs is selected: ID or ID Step. After choosing from the program list, the operator can set up total feed volume, individual cycle feed volume, feed speed, spindle RPM, workhead RPM, and grinding length. Finally, users can enter one of the pre-loaded dressing programs: ID dressing. After entering the desired dressing program, users can set dressing volume and off-set volume. This function not only reduces time spent adjusting tools, but also reduces the potential for accidental input errors. **JAGURA** Dialogue HMI is your best grinding solution. It greatly improves efficiency and assures production of the finest quality parts, while employing the most user friendly operation.



Main Menu



Dressing Rates



Grinding Rates



Link Cycle

Grinding example:

OD:

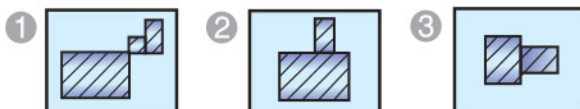

ID:



CNC Software & Dialogue Hmi (Human Machine Interface)

JAGURA CNC Series Internal & cylindrical grinding machines are specially designed for ID & OD profile grinding. The CNC control system is constructed by Mitsubishi but it employs the exclusive advanced software developed by **JAGURA**. Unlike the traditional CNC systems, utilizing complicated G and M codes, **JAGURA Dialogue HMI** is easy to both learn and use, thereby saving **JAGURA CNC** users valuable training time as well as money. The **JAGURA Dialogue HMI** is divided into 4 main sections: Main Menu, Dressing Programs, Grinding Path Programs, and Program Links. Users simply select a dressing pattern and grinding path, enter the processing parameters, and the machine can start to work. **JAGURA Dialogue HMI** is the best solution for grinding, especially grinding complicated profiles. The graphic directory enables the user to divide complicated grinding processes into individual stages. First, one of the pre-loaded grinding programs is selected: ID, Taper, Radius grinding. After choosing from the program list, the operator can set up total feed volume, individual cycle feed volume, feed speed, spindle RPM, workhead RPM, and grinding length. Finally, users can enter one of the pre-loaded dressing programs: ID, Taper, Radius, ID profile dressing. After entering the desired dressing program, users can set dressing volume and off-set volume. This function not only reduces time spent adjusting tools, but also reduces the potential for accidental input errors. **JAGURA Dialogue HMI** is your best grinding solution. Since it can be readily integrated with most ancillary automation e.g. loaders / unloaders and gauging, it greatly improves efficiency and assures production of the finest quality parts, while employing the most user friendly operation.

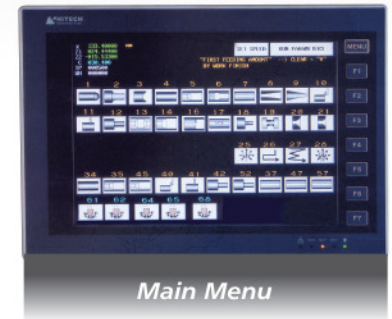

Main Menu

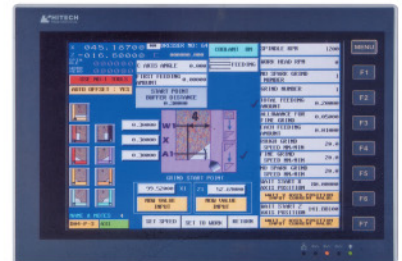

Dressing Rates



Grinding Rates



Link Cycle

Grinding example:

OD:



ID:

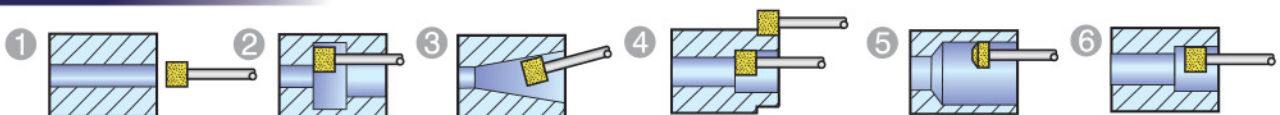

Internal & Cylindrical grinding machine

In-line series (3 Axis) ■ ICG2512 SL20 ■ ICG2512 SL11



Model		ICG-2512	
Clamping diameters		250mm	250mm
Max.grinding length		120mm	200mm
Max. trave	X axis	500mm	500mm
	Z1 axis	260mm	500mm
	Z2 axis	260mm	500mm
Min. feeding unit	X axis	0.001mm	0.001mm
	Z1 axis	0.001mm	0.001mm
	Z2 axis	0.001mm	0.001mm
Table speed	X axis	0-6m/min	0-6m/min
	Z1 axis	0-6m/min	0-6m/min
	Z2 axis	0-6m/min	0-6m/min
Workhead speed		0-550rpm	0-550rpm
Spindle speed		ID/10000-50000rpm (According to workpiece) OD/3440rpm	ID/10000-50000rpm (According to workpiece) OD/3440rpm
Motor	Workhead	2HP	2HP
	Spindle	ID/2HP OD/2HP	ID/2HP OD/2HP
	X axis	2KW	2KW
	Z1 axis	1KW	1KW
	Z2 axis	1KW	1KW
Machine dimensions(LxWxH)		2300x1950x2000	2300x1950x2000
Weight		About 4350 kgs	About 4650 kgs

Standard accessories: 1. Tool box and accessories1set.
2. Coolant system

* All specifications and design are subject to change without notice.

Spindle arrangement example:

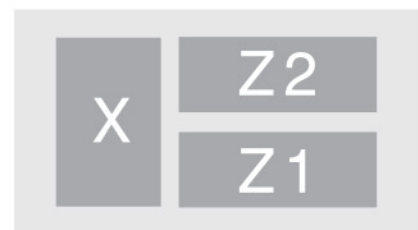
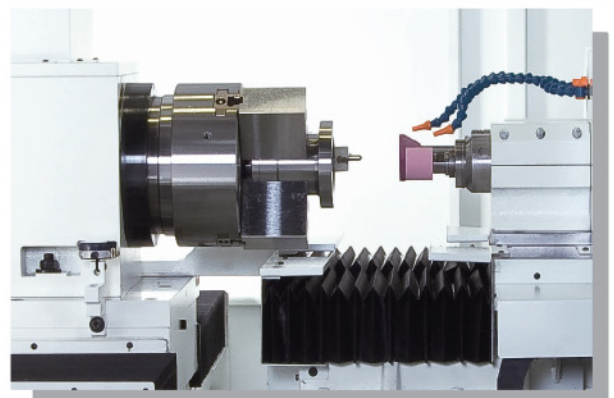

3 Axis

SL 20
Spindle —┐
In-Line —┐ ID —┐ OD

Internal & Cylindrical grinding machine

In-line series (3 Axis) ■ ICG2012 SL20 ■ ICG2012 SL11

■ ICG2012 SL21 (Customized)



Model		ICG-2012	
Clamping diameters		200mm	200mm
Max.grinding length		120mm	200mm
Max. trave	X axis	500mm	500mm
	Z1 axis	260mm	500mm
	Z2 axis	260mm	500mm
Min. feeding unit	X axis	0.001mm	0.001mm
	Z1 axis	0.001mm	0.001mm
	Z2 axis	0.001mm	0.001mm
Table speed	X axis	0-6m/min	0-6m/min
	Z1 axis	0-6m/min	0-6m/min
	Z2 axis	0-6m/min	0-6m/min
Workhead speed		0-550rpm	0-550rpm
Spindle speed		ID/10000-50000rpm (According to workpiece) OD/3440rpm	ID/10000-50000rpm (According to workpiece) OD/3440rpm
Motor	Workhead	2HP	2HP
	Spindle	ID/2HP OD/2HP	ID/2HP OD/2HP
	X axis	2KW	2KW
	Z1 axis	1KW	1KW
Z2 axis	1KW	1KW	
Machine dimensions(LxWxH)		2300x1950x2000	2300x1950x2000
Weight		About 4150 kgs	About 4450 kgs

Standard accessories: 1. Tool box and accessories1set.
2. Coolant system

* All specifications and design are subject to change without notice.

Spindle arrangement example:

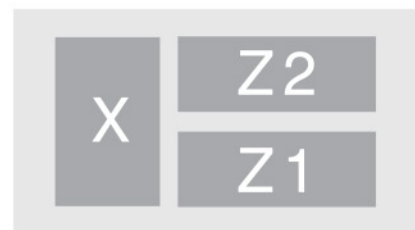
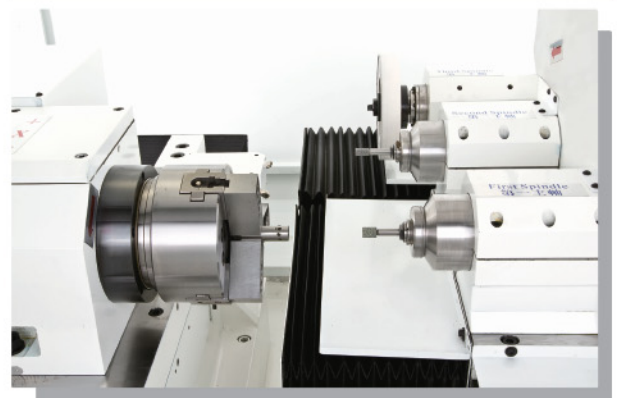

3 Axis

SL21
Spindle ┌
In-Line └ ID ┌ OD

Internal & Cylindrical grinding machine

In-line series (3 Axis)
(Customized)

■ ICG1512 SL20

■ ICG1512 SL11

■ ICG2012 SL20

■ ICG2012 SL11



■ Adjustable workhead for long workpiece
(Customized)

Model		ICG-1512	ICG-2012
Clamping diameters		150mm	200mm
Max. Length of workpiece		230mm	230mm
Max. grinding length		120mm	120mm
Max. travel	X axis	500mm	500mm
	Z1 axis	260mm	260mm
	Z2 axis	260mm	260mm
Min. feeding unit	X axis	0.001mm	0.001mm
	Z1 axis	0.001mm	0.001mm
	Z2 axis	0.001mm	0.001mm
Table speed	X axis	0-6m/min	0-6m/min
	Z1 axis	0-6m/min	0-6m/min
	Z2 axis	0-6m/min	0-6m/min
Workhead speed		0-550rpm	0-550rpm
Spindle speed		ID/10000-50000rpm (According to workpiece) OD/3440rpm	ID/10000-50000rpm (According to workpiece) OD/3440rpm
Motor	Workhead	1HP	1HP
	Spindle	ID/3HP OD/3HP	ID/5HP OD/5HP
	X axis	1kw	1kw
	Z1 axis	1kw	1kw
	Z2 axis	1kw	1kw
Machine dimensions(LxWxH)		2100x1700x2000	2300x1900x2000
Weight		About 4000 kgs	About 4250 kgs

Standard accessories: 1. Tool box and accessoriesx1set.
2. Coolant system

* All specifications and design are subject to change without notice.

Spindle arrangement example:

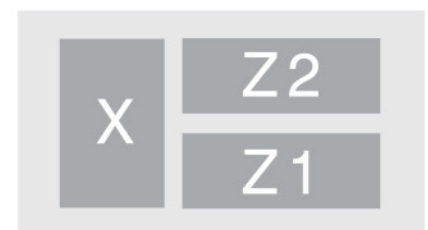
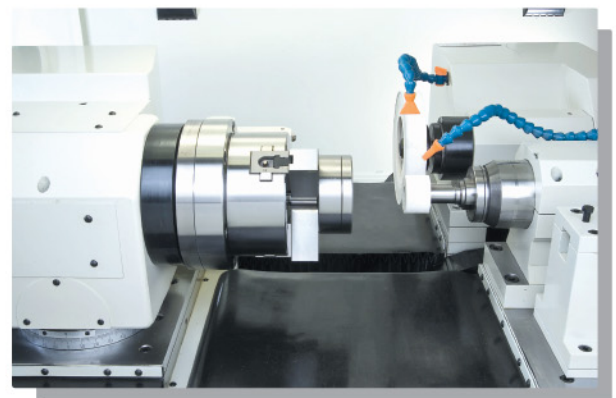

3 Axis

SL11
Spindle ┌ ┐ ┌ ID ┌ OD
In-Line └ ┘ └ └

Internal & Cylindrical grinding machine

In-line series (3 Axis) ■ ICG1512 SL20 ■ ICG1512 SL11



Model	ICG-1512	
Clamping diameters	150mm	
Max.grinding length	120mm	
Max. trave	X axis	320mm
	Z1 axis	260mm
	Z2 axis	260mm
Min. feeding unit	X axis	0.001mm
	Z1 axis	0.001mm
	Z2 axis	0.001mm
Table speed	X axis	0-6m/min
	Z1 axis	0-6m/min
	Z2 axis	0-6m/min
Workhead speed	0-550rpm	
Spindle speed	ID/10000-50000rpm(According to workpiece) OD/3440rpm	
Motor	Workhead	1HP
	Spindle	ID/2HP OD/2HP
	X axis	1kw
	Z1 axis	1kw
	Z2 axis	1kw
Machine dimensions(LxWxH)	2100x1700x2000	
Weight	About 3800 kgs	

Standard accessories: 1. Tool box and accessoriesx1set.
2. Coolant system

* All specifications and design are subject to change without notice.

Spindle arrangement example:

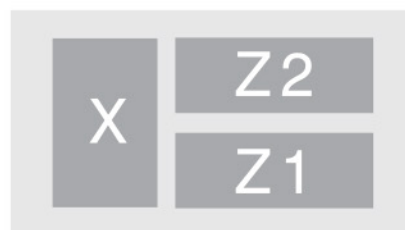
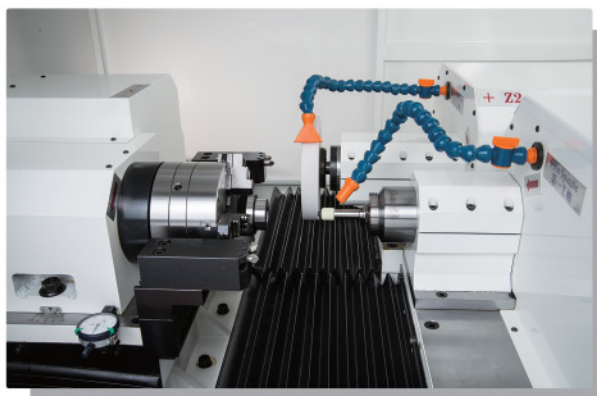

SL 11
Spindle ┌
In-Line ┌ ID ┌ OD

In-Line series optional attachment

1. Linear scale feedback

5. Soft jaw turning device

8. Touch probe gauge

11. Magnetic & paper filter

2. Hydraulic chuck 6",8"
(Hollow rotary/Solid rotary)

9. Magnetic coolant separator



3. High frequency spindle

6. C-Axis (CNC only)

12. Vacuum dust collector



Nakanishi
60000rpm
80000rpm



10. Paper coolant separator

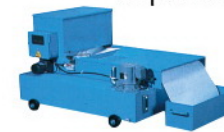

4. Rotary dresser

7. Quick fixtures for gears

13. Oil Mist separator



Clamping Application

1. Hydraulic chuck 6",8"
(Hollow rotary/Solid rotary)

2. Magnetic table workhead

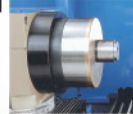

3. Roller workhead



4. Collet workhead



5. Diaphragm chuck



6. Eccentric jig



7. Clamping in pitch cycle jig

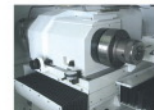

INTERNAL GRINDING SPINDLES

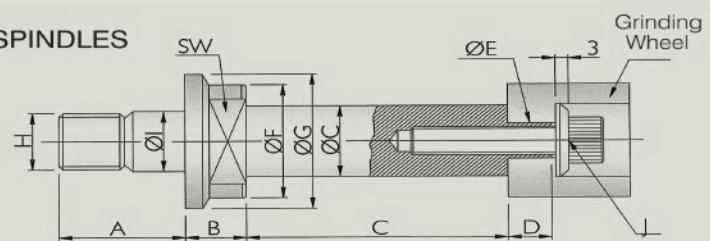

Grinding	Grease type	A	B	C	D	E	F	G	H	I	J	SW	Oil mist type	Grinding hold
φ 70-φ 150	8,000rpm	42	16	φ 40x100 φ 40x85 φ 40x55	12	φ 12	φ 50	φ 58	M26x2P	φ 28	M8x1.25P	41		
φ 25-φ 60	10,000rpm	29	14	φ 30x90 φ 25x70 φ 20x60	10	φ 10	φ 32	φ 38	M16x1.5P	φ 17	M8x1.25P	24	20,000rpm	φ 24-φ 40
φ 20-φ 30	20,000rpm	28	11	φ 24x80 φ 20x60 φ 16x40	8	φ 8	φ 26	φ 32	M14x1.5P	φ 15	M6x1.0P	19	30,000rpm	φ 15-φ 25
φ 6-φ 15	30,000rpm	21	9	φ 16x40 φ 13x30 φ 10x25	6	φ 6	φ 21	φ 26	M10x1.5P	φ 10.5	M4x0.7P	17	40,000rpm	φ 12-φ 16
φ 3-φ 10	40,000rpm	20	8	φ 12x35 φ 10x30 φ 8x25	X	X	φ 18	φ 23	M8x1.25P	φ 8.5	M4x0.7P	14	50,000rpm	φ 9-φ 13
φ 1.5-φ 6	50,000rpm	18	7	φ 8x30 φ 7x25 φ 6x20	X	X	φ 15	φ 20	M7x1P	φ 7.5	M4x0.7P	11	60,000rpm	φ 7-φ 10
		13	6	φ 6.7x25 φ 6x20 φ 5.7x15	X	X	φ 11	φ 14	M5x0.8P	φ 5.5	M4x0.7P M3x0.5P	8	80,000rpm	φ 6-φ 8

* All specifications and design are subject to change without notice.

Internal & Cylindrical grinding machine

Customized machine

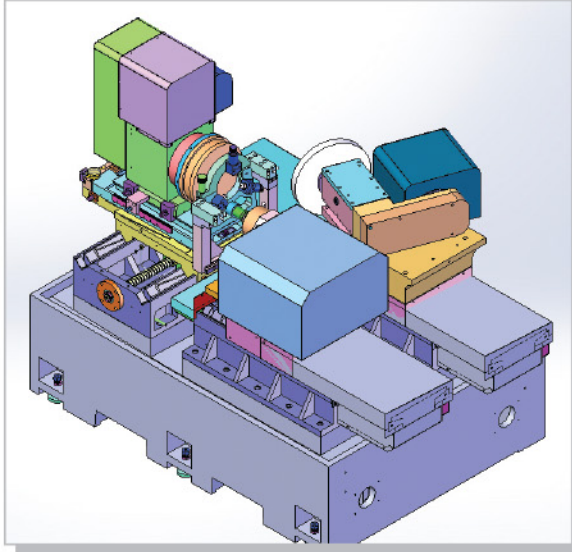

Spindle Arrangement

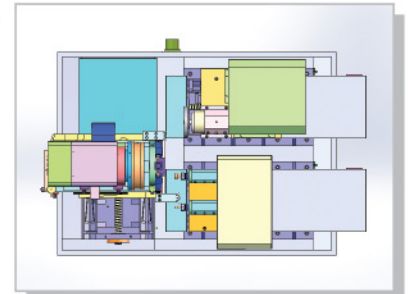
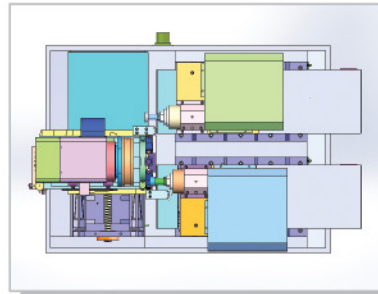
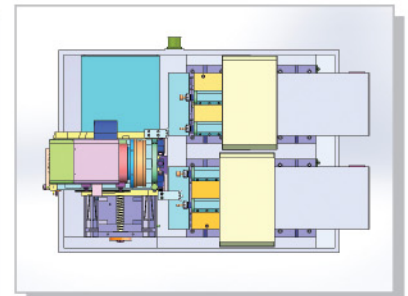
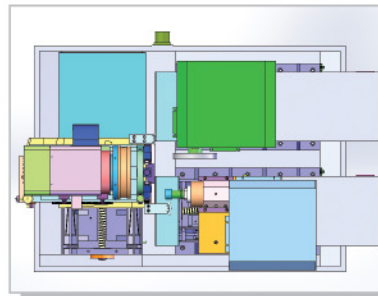
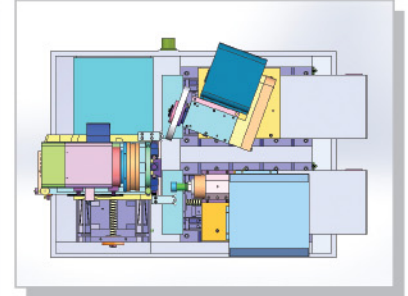
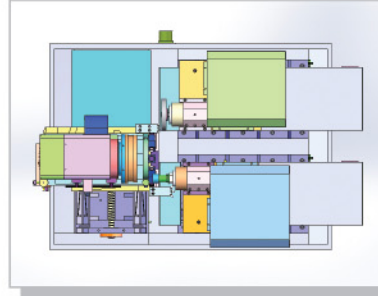

**In-Line Series
(SL)**

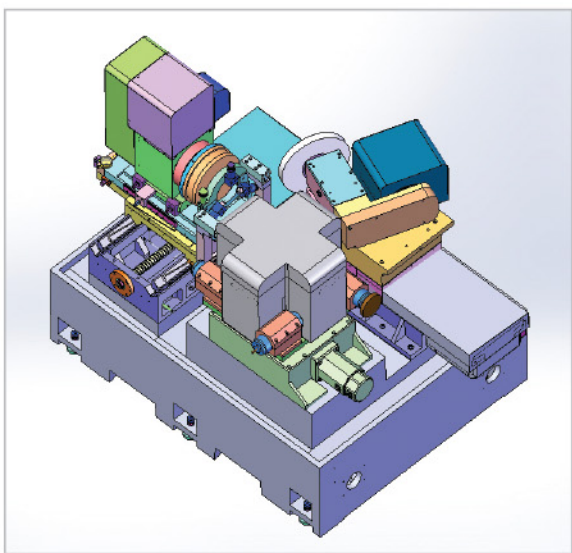

Spindle Arrangement

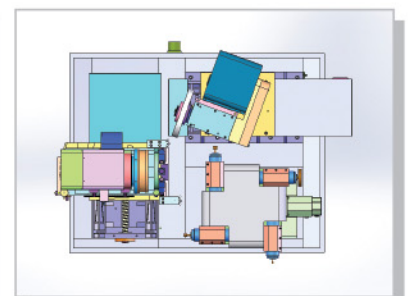
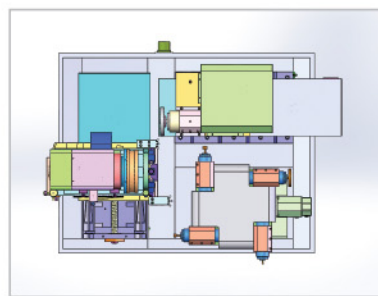

**Rotary Series
(SR)**